

### DESCRIPTION

Silicon N-channel enhancement mode vertical D-MOS transistor designed for large signal amplifier applications in the VHF frequency range.

### FEATURES

- Output Power: 60 W
- Power Gain: 13 dB Min@175M, 28V
- Efficiency: 60% Min

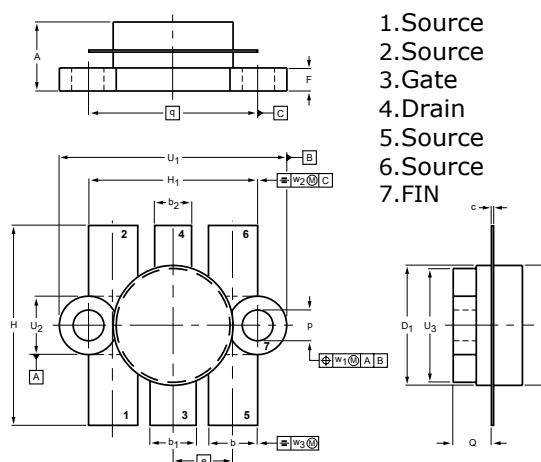

- 1.Source
- 2.Source
- 3.Gate
- 4.Drain
- 5.Source
- 6.Source
- 7.FIN

### DIMENSIONS

NOTE: ALL ELECTRODES ARE ISOLATED FROM FLANGE.

UNIT	A	b	b <sub>1</sub>	b <sub>2</sub>	c	D	D <sub>1</sub>	e	F	H	H <sub>1</sub>	p	Q	q	U <sub>1</sub>	U <sub>2</sub>	U <sub>3</sub>	w <sub>1</sub>	w <sub>2</sub>	w <sub>3</sub>
mm	7.39 6.32	5.59 5.33	5.34 5.08	4.07 3.81	0.18 0.07	12.86 12.59	12.83 12.57	6.48	2.54 2.28	22.10 21.08	18.55 18.28	3.31 2.97	4.58 3.98	18.42	25.23 23.95	6.48 6.07	12.76 12.06	0.51	1.02	0.26
inches	0.291 0.249	0.220 0.210	0.210 0.200	0.160 0.150	0.007 0.003	0.505 0.496	0.505 0.495	0.255	0.100 0.090	0.870 0.830	0.730 0.720	0.130 0.117	0.180 0.157	0.725	0.993 0.943	0.255 0.239	0.502 0.475	0.02	0.04	0.01

### MAXIMUM RATINGS

CHARACTERISTICS	SYMBOL	RATINGS	UNITS
Drain-Source Voltage	V <sub>DSS</sub>	65	V
Gate-Source Voltage	V <sub>GS</sub>	±20	V
Drain Current — Continuous	I <sub>D</sub>	12	A
Total Device Dissipation	P <sub>D</sub>	160	W
Junction Temperature	T <sub>J</sub>	200	°C
Storage Temperature Range	T <sub>STG</sub>	-65 to 150	°C

### ELECTRICAL CHARACTERISTICS

CHARACTERISTICS	SYMBOL	TEST CONDITIONS	MIN.	TYP.	MAX.	UNITS
Drain-Source Breakdown Voltage	V <sub>(BR)DSS</sub>	I <sub>D</sub> =15mA, V <sub>GS</sub> =0	65	-	-	V
Zero Gate Voltage Drain Current	I <sub>DSS</sub>	V <sub>GS</sub> =0V, V <sub>DS</sub> =28V	-	-	3.0	mA
Gate-Source Leakage Current	I <sub>GSS</sub>	±V <sub>GS</sub> =20V, V <sub>DS</sub> =0V	-	-	3.0	uA
Gate Threshold Voltage	V <sub>GS(th)</sub>	V <sub>DS</sub> = 10 V, I <sub>D</sub> = 300mA	2.0	-	6.0	V
Forward Transconductance	g <sub>fs</sub>	V <sub>DS</sub> = 10 V, I <sub>D</sub> = 3A	1.5	-	-	S
Input Capacitance	C <sub>iss</sub>	V <sub>DS</sub> = 28V, V <sub>GS</sub> = 0V, f = 1.0 MHz	-	140	-	pF
Output Capacitance	C <sub>oss</sub>		-	125	-	pF
Reverse Transfer Capacitance	C <sub>rss</sub>		-	26	-	pF
Common Source Power Gain	G <sub>PS</sub>	V <sub>DD</sub> =28V, P <sub>OUT</sub> =60W, f=175MH	13.0	-	-	dB
Collector Efficiency	η <sub>C</sub>		60	-	-	%

Note : Above parameters , ratings , limits and conditions are subject to change.